

USERS MANUAL MODEL 31

HAND HELD POWER ANALYZER SINGLE- AND THREE PHASE

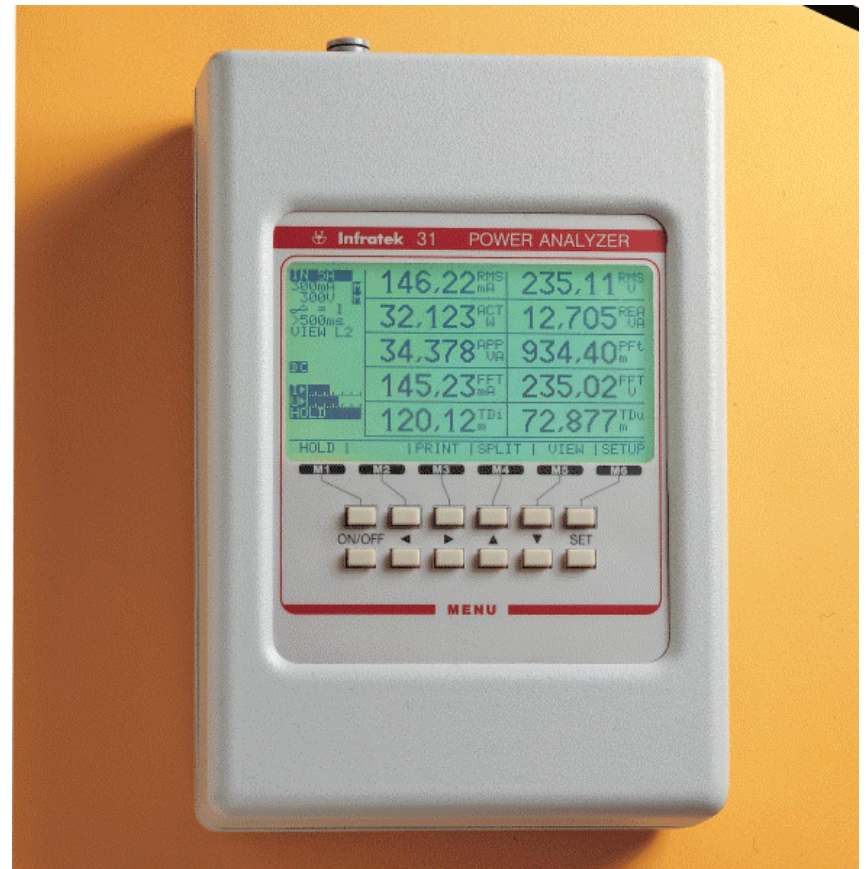

TABLE OF CONTENTS

1. SAFETY

1.1 Warnings

2. INTRODUCING THE HAND HELD POWER ANALYZER

2.1 Instrument Versions, Options, Accessories

2.2 Specifications

3. MATHEMATICAL DEFINITIONS USED BY THE POWER ANALYZER

4. GETTING STARTED

4.1 Front Panel and Rear Panel

4.2 Line Voltage Selection of the Charger

4.3 Turning the Power Analyzer on

4.4 Using the Function Keys

4.5 Selecting the Correct Current Input

4.6 Taking Basic Measurements

5. OPERATING THE POWER ANALYZER FROM THE FRONT PANEL

5.2 Operating Philosophy

5.3 Operations Controlled by the Side Menus

5.3.1 Current Input Selection

5.2.2 Range Selection, Auto Range Selection

5.2.3 Selecting Synchronization / 2W, 3W Configuration

5.2.4 Selecting Measurement Time and Special Functions

5.2.5 Selecting IEC1000-3-2, or Logging

5.2.6 Selecting Various Display Modes

5.2.7 Selecting the Graphics in the VIEWSUM-Display-Mode

5.3 Operations Controlled by the Bottom Line Menus

5.3.1 Main Menus

5.3.2 Main Menu <HOLD>

5.3.3 Main Menu <AC+DC>

5.3.4 Main Menu <SPLIT>

5.3.5 Main Menu <VIEW>

5.3.6 Main Menu <SETUP>

5.4 Operations Controlled by the Numeric Display Field

5.4.1 The Measurement Function Selection Table

5.4.2 Selecting RMS-Values

5.4.3 Selecting Min, MAX, Peak, AND CF

5.4.4 Selecting Power Values

5.4.5 Selecting and Resetting Energy Values

5.4.6 Selecting Mechanical Values

5.4.7 Selecting Frequency

5.4.8 Selecting Power Factor (PF)

5.4.9 Selecting THD (Total Harmonic Distortion)

5.4.10 Selecting FFT Values, Harmonics 1-63

5.4.11 Selecting Magnitude of Impedance 1-63

5.4.12 Selecting Phase Angle of Harmonic Impedance 1-63

6. OPERATING THE POWER ANALYZER USING THE COMPUTER INTERFACE

6.1 Introduction

6.2 Local and Remote Operations

6.3 RS-232 Computer Interface

6.4 Setting Interface Parameters

6.5 Cabling the Power Analyzer to a Host

6.6 How the Power Analyzer Processes Input

6.6.1 Input Terminator

6.6.2 Sending Commands to the Power Analyzer

6.6.3 How the Power Analyzer Processes Output

6.6.4 Optimizing Speed for Data Transfer

6.7 Operating Several Instruments on RS-232 from one Computer

6.7.1 Status Register Definition

6.8 Computer Interface Command Set

7. THE POWER ANALYZER OPTIONS

7.1 Option 01: RS-232 Interface, and Operating Software

7.1.1 RS-232 Interface and Operating Software

7.2 Option 02: RS-232 Interface, Operating Software Data Logging, and IEC-Testing

7.3 Option 03: 0-100A Three Phase Current Sensor Module

8. EPROM REPLACEMENT, POWER ANALYZER CALIBRATION

8.1 EPROM Replacement

8.2 Power Analyzer Calibration

8.2.1 Calibration Cycle

8.2.2 Equipment Needed

8.2.3 Preparing for Calibration

8.2.4 Voltage Calibration, Current Calibration, Clamp Calibration

1. SAFETY

Before using the Power Analyzer, read the following safety information carefully. In this manual „**WARNING**“ is reserved for conditions that pose hazards to the user; „**CAUTION**“ is reserved for conditions that may damage your instrument.

- Avoid working alone.
- Follow all safety procedures for equipment being tested.
- Inspect the test leads for damaged insulation.
- Be sure the Power Analyzer is in good operating condition.
- To avoid electrical shock, use caution when working above 30V dc or rms.
- Disconnect the live test leads before disconnecting the common test leads.
- When making a current- or power measurement, turn the circuit power off before connecting the Power Analyzer in the circuit.
- Switching on inductive loads means large inrush currents. Take precautions to avoid overloading the current channels by shorting the start-up currents across the current inputs.
- Switching off inductive loads or switching on rotating loads means large voltages or extremely fast changing voltages on the Power Analyzer input terminals. Such conditions may damage the instrument and are potentially hazardous.
- To comply with EN50081-1 the current- and voltage test leads must form 6 windings through ferrite torroid Siemens B64290-L40-X830 or equivalent. (This measure will also enhance immunity with respect to fast common mode transients), the RS-232 interface cable must be shielded and must form 1 winding through Fair-rite VO 0444176451.
- 1kV burst test: use shielded input- and output cables.
- The Power Analyzer complies with the safety standards IEC 1010-1, EN 61010-1.

1.1 WARNINGS

- Before reading the manual or before using this instrument read carefully the warnings below and make sure you understand them.
- **WARNING: Line Power**
To avoid shock hazard, connect the instrument power cord to a power receptacle with earth ground.
- **WARNING**
The maximum floating voltage above earth ground on the current input terminals and the voltage Lo-input terminals is 600V. Exceeding these limits poses a hazard to the meter and operator.
- **WARNING**
Qualified personnel must operate this instrument.
- **WARNING**
Refer all servicing of this instrument to qualified personnel. Before opening case disconnect all leads connected to the instrument and finally disconnect the power line cord.
- **WARNING**
The specifications given in this manual solely describe the technical properties of the instrument. They do not imply any other properties unless it is explicitly said so.
- **WARNING**
Use of this instrument in life support systems and in systems for people transportation must be expressly authorized.
The manufacturer of this Power Analyzer must sign the authorization.
- **WARNING**
Do not operate the front panel keys with pointed objects. A damaged key may pose shock hazard.
If you observe a damaged front panel key, please report this to your nearest Infratek representative and return the instrument for repair.

2. INTRODUCING THE HAND HELD POWER ANALYZER

WARNING

Read the „Power Analyzer Safety“ in section 1 of this manual before using the instrument. This 1- and 3-phase Power Analyzer is designed for bench-top, field service, and system application.

Some features provided by the Power Analyzer are:

- Blue LCD monitor, 108 x 56mm (240x128 pixels).
- Fully menu controlled operation with only 11 soft keys.
- Meter mode and graphics mode.
- Measures and computes all electrical quantities of current, voltage, power, energy and harmonics of current, voltage, and power simultaneously.
- Frequency measurement 0.1Hz - 50kHz.
- AC-, and AC+DC-coupling for individual quantities.
- Built-in integrator.
- Harmonic Analysis of current, voltage, power, and impedance (Mag. / Phase)
- Bar graph and wave form display.
- Wide voltage- and current range (20mA - 50A).

Depending on instrument version the following additional measurement functions are available:

- Line-to-line voltage measurement.
- IEC1000-3-2, simultaneous current harmonic testing on three phases supported by Windows Operating Software.
- Data Logging function supported by windows operating software. Plots of measured quantities (3 per phase) versus, time of frequency (5Hz - 400Hz) can be generated and plotted. Maximum values during logging pass are stored and can be viewed on the display by entering HOLD.
- Motor testing supported by Windows Operating Software. Mechanical input- and output power, torque, speed, efficiency, are determined.

2.1 INSTRUMENT VERSIONS, OPTIONS, ACCESSORIES

Model 31-1/0.4L	Single Phase Power Analyzer, 0.4 % accuracy, saves 12 instrument settings, battery charger/supply, carrying case, no data logging, no harmonics
Model 31-1/0.4	Single Phase Power Analyzer, 0.4 % accuracy, saves 12 instrument settings, battery charger/supply, carrying case, includes harmonics
Model 31-1/0.2	Single Phase Power Analyzer, 0.2 % accuracy, saves 12 instrument settings, battery charger/supply, carrying case, includes harmonics, and IEC1000-3-2 testing
Model 31-1/0.1	Single Phase Power Analyzer, 0.1 % accuracy, saves 12 instrument settings, battery charger/supply, carrying case, includes harmonics, IEC1000-3-2 testing, and data logging
Model 31-3/0.4L	Three Phase Power Analyzer, 0.4 % accuracy, saves 12 instrument settings, battery charger/supply, carrying case, no line-to-line, no data logging, no harmonics
Model 31-3/0.4	Three Phase Power Analyzer, 0.4 % accuracy, saves 12 instrument settings, battery charger/supply, carrying case, includes harmonics and line-to-line
Model 31-3/0.2	Three Phase Power Analyzer, 0.2 % accuracy, saves 12 instrument settings, battery charger/supply, carrying case, includes harmonics, line-to-line, and IEC1000-3-2 testing.
Model 31-3/0.1	Three Phase Power Analyzer, 0.1 % accuracy, saves 12 instrument settings, battery charger/supply, carrying case, includes harmonics, line-to-line, and IEC1000-3-2 testing.
Model 31-3/0.1M	Three Phase Power Analyzer, 0.1 % accuracy, saves 12 instrument settings, includes line-to-line, data logging, IEC1000-3-2 testing, calculation of motor Parameters, RS-232 interface, operating software under Windows 95, 98, NT, 2000, ME, XP and charger/supply, carrying case.

- Option 01 RS-232 Interface, external synchronization input, Windows Operating Software (95, 98, NT, 2000, ME, XP) without data logging capabilities, without IEC1000-3-2
- Option 02 RS-232 Interface, external synchronization input, trigger input, Windows Operating Software (95, 98, NT, 2000, ME, XP) including software for high speed data logging, and IEC1000-3-2 testing
- Option 03 0-100A three phase current sensor module including supply
- Option 04 0-300A, 0-3000A flexible current clamp with connector to clamp inputs of Power Analyzer (1 per phase), 1 % at 50/60 Hz
- ACS1: Current clamp with connector to Model 31 clamp input, 0-200A / 0-1000A DC-1kHz, 2%
- ACS2: Current clamp with connector to Model 31 clamp input, 0-20A / 0-200A, DC-20kHz, 1%
- ACS4: Set of test leads, max. 32A, 1.5m (2 red, 2 black)
- ACS5: Clamp input connector
- ACS6: Service Manual
- ACS7: Official Calibration Certificate from SCS (Swiss Calibration Service)

2.2 SPECIFICATIONS

Voltage	7 ranges: 1 V, 3 V, 10 V, 30 V, 100 V, 300 V, 1000 V	1 Hz-100 kHz / DC-100 kHz
	Frequency range: DG100 kHz	Coupling: AC/AC+DC
	Crest Factor 3:1 at 50 % full scale	Common Mode 50 Hz/100 kHz
	Built-in star point network 500 Ω	Maximum Input: Hi to Lo/Lo to case
Current	Accuracy 23° ±3 °K; rms, rdg=reading	Accuracy Grades: k=1, k=2, k=4
	1 Hz-1 kHz	±k(0.1 % rdg ±0.07 % range)
	1 kHz-10 kHz	±k(0.3 % rdg ±0.2 % range + 0.02 % / kHz rdg)
	10 kHz-100 kHz	±k(0.05 % / kHz rdg + 0.3 % range)
	10 ranges: 100 mA, 300 mA, 1, 3, 10 A; 1, 3, 10, 30, 100 A.	Clamp: 1 A-1000 A
	Frequency range DG100 kHz	Coupling: AC, AC+DC
	Crest Factor 3:1 at 50 % full scale	Common Mode 50 Hz/100 kHz
	3 A input 3 A cont./10 A 5 s; 50 A input: 40 A cont./50 A 20 s.	RI=30 mΩ/3 mΩ
	Accuracy 23° ±3 °K; rms, rdg=reading, rng=range	
	50 A/Clamp Input	3 A Input
Power	1 Hz-500 Hz	±k(0.1 % rdg + 0.1 % rng)
	500 Hz-2 kHz	±k(0.6 % rdg + 0.6 % rng)
	2 kHz-10 kHz	±k(0.8 % rdg + 0.8 % rng)*
	10 kHz-100 kHz	±k(0.1 % / kHz rdg + 0.8 % rng)*
	Lowest range multiply percentage figures by 2. *typical	
	70 ranges corresponding to the products of voltage ranges times current ranges	DC-100 kHz
	Accuracy 23° ±3 °K; 50 A/Clamp Input, 3 A Input	
	1 Hz-1 kHz	Add accuracy percentage figures of current and voltage input
	1 kHz-100 kHz	Add accuracy percentage figures of current and voltage input, add ±2 % (1-PF)/ kHz of range
		PF = 0 to ±1

2-4

Computed Values	Reactive Power: $Var = \pm(VA^2 - W^2)^{1/2}$; Apparent Power: $VA = ArmsVrms$; Power Factor: $PF = W/VA$; Crest Factor: $CF = Ap/Arms$, $Vp/Vrms$; Maximum: Ap , Vp ; Minimum: $-Ap$, $-Vp$; PtP : Maximum- Minimum; Impedance: $Z = Vrms/Arms$; Total harm. Dist., $THD1 = (Irm^2 - I_{fund}^2)^{1/2} / I_{rms}$, $THD2 = (I^2 - I_n^2)^{1/2} / I_{rms}$.	Add accuracy percentage figures of values involved in computation.
Mechanical Values	Total Input Power, Nm/s; Output Power to load, Nm/s; Torque at axis of rotating machine, Nm; Speed, rpm; Efficiency $\eta = Output Power / Input Power$	Synchronous machines only.
Harmonic Analysis	Frequency range of fundamental 4 H \pm kHz	Harmonic 1-63
	Accuracy: harmonic current and voltage, same as rms current and rms voltage	
Frequency Integrator	Computed Values: harmonic power; harmonic phase angle (power factor); harmonic impedance.	Add accuracy percentage figures of values involved in computation.
	2 Hz-50 kHz; A; V: ±0.1 %	
Data Logging	Energy, Accuracy Wh, Vah; Basic accuracy of integrated quantity	
Current Harmonics	Output values, speed, and duration is programmable; maximum speed: 10 values from a 3-phase system in 150 ms.	Range of signal frequency 5 Hz to 400 Hz
	Current harmonics in a 3-phase system are determined according to IEC1000-3-2	
Display Power/Battery Dielectric Strength Dimensions	Display: Blue liquid crystal graphic display with EL backlight	58x108mm; 128x240 pixels
	Charger: AC, 5060 Hz, 115/230 V, 0.2 AF, 10 VA; sealed Lead gel battery, 6 hours	3 kV; 2 kV; 3 kV 50 Hz/1 min
Options	Dielectric Strength: Current inputs to case; Voltage inputs to case; Input to case	75x160x245mm; 1.5kg
	Dimensions: H x W x D RS-232 Interface Windows operating software, 95, 98, NT, 2000, ME, XP Current clamps 0200 A/0-400 A	

2-5

3. MATHEMATICAL DEFINITIONS USED BY THE POWER ANALYZER

RMS-, rectified mean-, mean-, maximum-, minimum-, and peak-to-peak values apply to current and voltage.

Energies apply to real- and apparent power.

Total harmonic distortion applies to current and voltage.

RMS-value $(1/T \int_0^T i^2 dt)^{1/2}$; RMS of total and RMS of every harmonic (1-63)

RMS of line-to-line voltage $(1/T \int_0^T (U1-U2)^2 dt)^{1/2}$

Rectified mean $1/T \int_0^T |i| dt$

Mean value $1/T \int_0^T i dt$

Maximum max. (i) in averaging interval

Minimum min. (i) in averaging interval

Peak-to-peak max. (i) - min. (i) in averaging interval

Crest Factor Maximum / RMS-value

Frequency Number of zero crossings of current or voltage.

Average Power P $1/T \int_0^T u i dt$

Apparent Power S RMS current x RMS voltage

Reactive Power Q $\pm(S^2 - P^2)^{1/2}$

Reactive Power 3-phase $[(S1 + S2 + S3)^2 - (P1 + P2 + P3)^2]^{1/2}$

Power Factor P/S
Power Factor 3-phase system $(P1 + P2 + P3) / S1 + S2 + S3)$

Energies $\int_0^t xdt$ x = P, S

Total harm. Distortion THD1 $(I_{rms}^2 - I_{fund}^2)^{1/2} / I_{rms}$

Total harm. Distortion THD2 $\Sigma(I_n^2)^{1/2} / I_{rms}$; n = 2, ... 4Hz to 380Hz

Magnitude of Impedance Mag Vn/In; n = 1, 2, ... 63

Phase Angle of Impedance Phase Vn/In; n = 1 → Power Factor of fundamental

Mechanical Input Power Pmin P1 + P2 + P3 [Nm/s]

Mechanical Output Power Pmout P1 + P2 + P3 – Ploss [Nm/s]

Torque applied to load T = Pmout • poles / 4 • 3.1416 • frequency

Efficiency $\eta = 1 - P_{loss} / P_{min}$

Slip S = 1 – fout / fin

Speed (internal) RPM 120 frequency / poles

3W-configuration Average- and sum-value from L1, L2, L3

2W-configuration Average- and sum-value from L1, L2

4. GETTING STARTED

This section explains how to prepare the Power Analyzer for operation, discusses general operating features, and explains some common measurements.

4.1 FRONT PANEL AND REAR PANEL

The front panel in figure 4.1 shows the graphic display in its configuration when the Power Analyzer starts up with a user defined recall number 1-12. The main menus at the bottom of the display are selected by pressing menu keys M1 through M6. Below the menu keys are 4 cursor control keys and one “SET” key. The cursor control keys are used to move the cursor up and down or to the right or to the left.

The basic operations are:

- Move the cursor in the side menu and press “SET”. A pull down menu is presented to select a new setting.
- Move the cursor right to any display number field and press “SET”. A measurement quantity selection table is presented to select a new quantity.

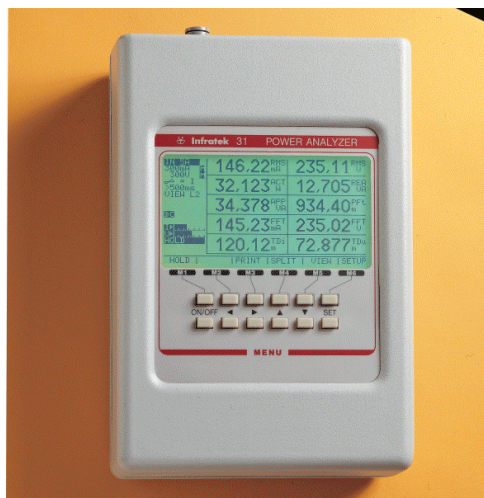

Figure 4.1: Power Analyzer Front Panel

The rear panel shown in figure 4.2 contains the input terminals on the left hand side. The Hi- and Lo-voltage terminals are in the middle. The current input terminals are to the left. Two red terminals for 3A and 50A and one common Lo terminal. The clamp input is equipped with a short circuit connector. When not in use, this short circuit connector must be installed.

The three phase Power Analyzer has the inputs for phase 1 (L1) at the top, phase 2 (L2) inputs are in the middle, and phase 3 (L3) inputs at the bottom.

On the right hand side of the rear panel is the RS-232 interface connector and next to it the input for the battery charger / or external supply.



Figure 4.2: Power Analyzer Rear Panel

4.2. LINE VOLTAGE SELECTION OF THE CHARGER

The line operating voltage is factory set. Before operating your Power Analyzer on line power please check the voltage setting written on the tag above the line receptacle. In case the voltage does not match the operating voltage of your country the voltage setting can be changed as shown below:

WARNING

Before changing the internal voltage setting disconnect all electrical connections to the Power Analyzer.

- Remove all connections to your Power Analyzer.
- Remove the cover of the charger case by removing 4 screws on top of the case.
- Change the jumper setting as shown in Figure 4.3.

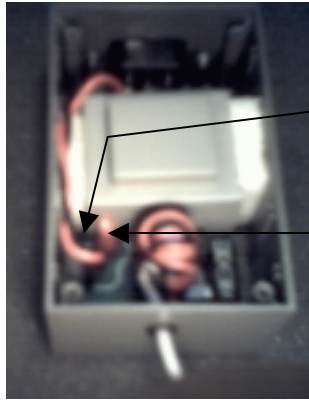

Position of Voltage Selector for 110V/60Hz operation (use pin in the middle and to the left)

Voltage Selector set for 230V/50Hz operation (use pin in the middle and to the right)

Figure 4.3: Position of Voltage Selector for 110V and 230V operation.

4.3 TURNING THE POWER ANALYZER ON

Insert the line cord into the receptacle on the charger. It will operate on the line voltage marked above the line cord receptacle.

Turn on the instrument by activating the on/off-switch located on the front panel.

Alternatively, you can operate the Power Analyzer on the internal batteries without external supply.

When the instrument is turned on the display is set to its factory start-up configuration (recall number 00) with most values set to zero for about 2 seconds. The Power Analyzer assumes its initial setting as follows: the first line of the display number field shows the RMS current and the RMS voltage. The second line shows power and frequency of current, and the third line shows apparent power and power factor.

The fourth and fifth lines are graphic area. At start-up the harmonic bar graph of current is displayed. The horizontal scale is numbered 0-59 referring to the harmonics of current (N=0 is the DC component) and the vertical scale gives the approximate magnitudes of the harmonics in mA or A.

Three phase instruments will display values from phase L1.

The side menu shows the following settings:

IN 5A	current input 5A (3A)
100mA A	100mA range in auto ranging
1V A	1V range in auto ranging
Syn = I	synchronization to current phase L1
>500 ms	500ms measurement time
VIEW L1	displays phase L1 values

The main menus along the bottom side of the display are:

| HOLD | | PRINT | SPLIT | VIEW | SETUP |

4.4 USING THE FUNCTION KEYS

Below the display are 2 rows of control keys. The top row contains 6 menu control keys **M1**, **M2**, **M3**, **M4**, **M5**, and **M6**. The bottom row contains 4 cursor control keys and 1 "SET" control key.

The basic use of the two key control fields is as follows:

The **cursor control keys** are used to move the cursor to the desired position on the display. Pressing the **SET-key** means that you want to modify this position; this can be a position to the very left of the display (side menu) such as 5A/50A input selection, or current range- or voltage range selection, or synchronization to I or U (current or voltage of phase L1), or selection of averaging time, or selection of phase L1, L2, L3, SUM, or ALL display.

When you move the cursor to the display number field the display can be reconfigured, that is, you can place at the selected position a different quantity.

The **menu control keys M1** through **M6** go with the 6 menus shown along the bottom of the display. These menus are dynamically changing, depending on the cursor position and other action you may take.

4.5 SELECTING THE CORRECT CURRENT INPUT

Before you apply current to the input terminals of the Power Analyzer you must know the approximate maximum rms value that will flow. Select the appropriate current input IN 5A or IN 50A. If you are in doubt select the IN 50A or even use current transducers.

This is how you select the desired current input. Move the cursor to the top of the side menu, press "SET". The current input selection pull down menu appears: **IN 5A / IN 50A / CLAMP**. Move the cursor to the desired input and press "SET". The side menu now shows the current input.

4.6 TAKING BASIC MEASUREMENTS

The following procedures describe the basics of taking common power measurements operating the Power Analyzer from the front panel. This information is provided for the user who needs to get started quickly.

WARNINGS

- Read the Power Analyzer safety before operating this instrument.
- Make sure when wiring the Power Analyzer in a circuit that you are using the current input (5A or 50A) you have selected with the front panel controls.
- To avoid electrical shock or damage to the Power Analyzer, do not apply more than 850V peak between any terminal and earth ground. The user should be well aware of the fact, that switching off inductive loads may generate extremely fast and high voltage transients exceeding above limits. To measure voltage, current, power and related quantities in a 3-phase circuit connect the test leads as shown in figure 4.4 and follow the procedure described below.

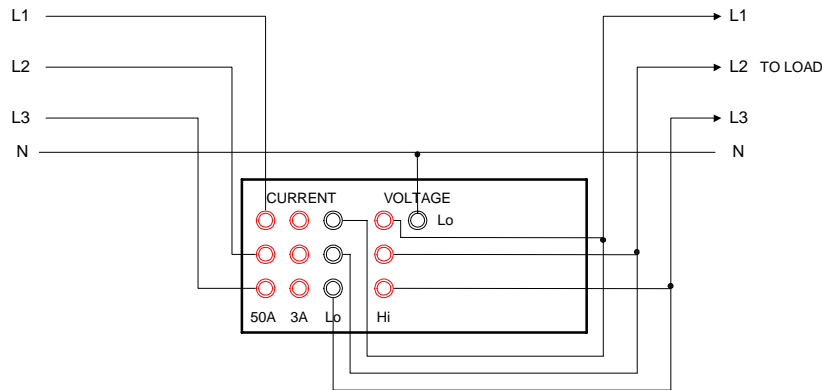

Figure 4.4: Wiring of the Power Analyzer in a 3-phase 4-wire circuit. The 3-Wattmeter connection is used. Total Power = P1+P2+P3. If no neutral is available leave voltage Lo unconnected. (Frequency inverters, star point network 500kΩ is built in)

- Turn off power in the circuit to be measured.
- Break the circuit in each phase and connect phase L1 to the current input 1, phase L2 to current input 2, and phase L3 to current input 3. The current flows from source to load; as a consequence you must connect the Hi current inputs to the source side and the Lo current inputs to the load side.
- L1, L2, and L3 are also connected to the Hi voltage inputs. The Lo voltage input terminal is connected to neutral in a 4-wire circuit. If you have no neutral available (3-wire circuit) connect the voltage Lo-terminal to the grounding post on the Power Analyzer, or alternatively, leave it open (star point network is built in the instrument).
- Switch on the Power Analyzer (it will be in automatic ranging). Select the correct current input **IN 5A** or **IN 50A** as described in 4.6.
- Turn on power to the load under test.
- The Power Analyzer will automatically select the voltage range and displays the following six electrical quantities (display top to bottom) RMS-current, RMS-voltage, power, frequency, apparent power, and power factor of phase L1. The bar graph of current shows the harmonic content of phase L1.
- Use the side menu to display values from phase L2, L3, SUM, and ALL.

5. OPERATING THE POWER ANALYZER FROM THE FRONT PANEL

Section 5 explains how to operate the Power Analyzer from the front panel. Depending on the instrument version not all functions described here may be available. You may want to configure the instrument to your personal needs going through the steps described in this section. Once you are done you may want to store your instrument settings at one of the 12 different locations. If you also set the **recall number** to the same location the Power Analyzer will start up at power-on in your personal instrument configuration. Six menu keys **M1** through **M6** below the display, four cursor control keys, and one **SET** key perform all operations. All front panel operations can just as well be achieved by using the computer interface.

5.1 OPERATING PHILOSOPHY

The display monitor is subdivided into the side menu field, the number- and graphics field, and the bottom line menu field (Figure 5.1). The cursor can be moved to the side menu field and the number field.

If you move the cursor to one of the side menu annunciators and press the **SET** key a pull-down menu is presented from which you can make a new choice. Moving the cursor in the pull-down menu to the desired value does this. Press the **SET** key again. The new setting becomes active and appears now as annunciator in the side menu.

If you move the cursor to the display number field and press the **SET** key a selection table of the available measurement values is presented from which you can make a new choice. Moving the cursor in the selection table to the desired value does this. Press the **SET** key again. The new measurement quantity now becomes active and appears now in the selected display number field.

Finally, the keys **M1** through **M6** operate the bottom-line menu field. The main menus **HOLD**, **AC+DC**, **PRINT**, **SPLIT**, **VIEW**, **SETUP** appear when the cursor is located in the side menu. When the cursor is located in the display number field a secondary menu appears matching the measurement quantity the cursor is pointing at. If the cursor is pointing at an FFT-value, for example, the bottom-line menu lets you alter the harmonic number shown in the annunciator in the middle section of the side menu field.

- Side menu field (annunciators)
- Number field
- Graphics field (none selected)
- Bottom-line menu field
- Menu keys M1 ... M6
- Cursor control keys

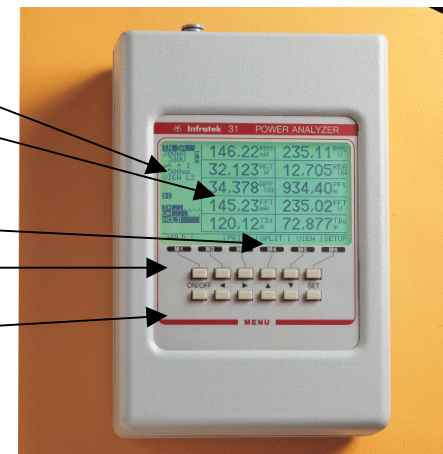

Figure 5.1 Power Analyzer Front Panel Controls

5.2 OPERATIONS CONTROLLED BY THE SIDE MENUS

The side menus control such functions as current input selection, range selection, measurement time and special functions selection, and display mode selection.

5.2.1 CURRENT INPUT SELECTION

You can choose from three different current inputs: **IN 5A**, **IN 50A**, and **CLAMP**. Move the cursor to the top annunciator showing the presently selected current input. Press the **SET** key to display the pull-down menu **IN 5A / IN 50A / CLAMP** for input selection. Now move the cursor to the desired input and press **SET**. With this action you return to the side menu. The top annunciator displays now the current input of your choice.

IN 5A, IN 50A: If you intend to use the high current input **IN 50A** make sure you do connect to this input. Although the inputs have high overload capabilities a connection to the low current input **IN 5A** by mistake may damage the Power Analyzer input circuitry. The following maximum currents should not be exceeded.

	IN 5A	IN 50A
Maximum continuous current	8A	40A
Maximum current 1 second	20A	100A

CLAMP input: The clamp inputs are provided for the measurement of large currents (>50A) by external transducers. These can be current clamps, Hall sensors with current or voltage output, or special current transformers (CT). Current shunts are not allowed because the clamps Low inputs are connected to the voltage Low in the Power Analyzer. The clamp input sensitivity is **1.000A display for 1mV applied**.

5.2.2 RANGE SELECTION, AUTO RANGE SELECTION

Current Ranging

To select a current range you move the cursor in the side menu to the current range annunciator and press the **SET** key. Depending on the selected current input one of the following pull-down menu will appear.

Selected input	Pull-down menu
IN 5A IN 50A CLAMP (1mV → 1A)	100mA/300mA/1A/3A/10A 1A/3A/10A/30A/100A 60mV/200mV/600mV/2V/6V

Move the cursor to the desired range and press **SET** to return to the side menu.

Auto Ranging

When you have set a range manually an inverse M to the right of the range annunciator is displayed indicating that current is in manual ranging. With menu key **M2** you can toggle the current input from manual ranging to auto ranging (indicated by an inverse A), and back to manual ranging. For all but a few measurements auto ranging will work fine. Manual ranging must be used for the data logging and dynamic torque measurement and for those measurements where occasional large current peaks cause an undesired up-and down ranging.

Voltage Ranging

To select a voltage range you move the cursor in the side menu to the voltage range annunciator and press the **SET** key. From the pull-down menu 1V/3V/10V/30V/100V/300V/1000V select the desired range with the cursor. Press **SET** to activate the range and return to the side menu. The inverse M to the right of the voltage range annunciator indicates manual ranging for the voltage inputs. For auto range selection proceed as described in “**Auto Ranging**” above.

NOTE: When you are using a three phase Power Analyzer all three channels are in the same voltage – and current range. If the signal level of one channel is much below the others you will still achieve good accuracy. The Power Analyzer exhibits excellent linearity for signal levels from 5 to 150 % of full scale.

5.2.3 SELECTING SYNCHRONIZATION / 2W, 3W-CONFIG.

The fourth annunciator from the top of the side menu indicates the selected measurement signal synchronization. Move the cursor to this position and press **SET**. The pull-down menu **Sync I / Sync U / EXT** is displayed. Move the cursor to the desired setting and press **SET** to return to the side menu. External synchronization is not available for this Power Analyzer.

Sync I: When you select **Sync I** the fundamental wave form of current L1 is used to measure frequency. Furthermore, the calculation of rms-, power-, and harmonic values is synchronized to the fundamental waveform. As a rule harmonic values are meaningless when the frequency display is unstable.

Sync U: When you select **Sync U** the fundamental waveform of voltage L1 is used to measure frequency. The calculation of rms-, power-, and harmonic values is synchronized to the fundamental waveform. Harmonic values are meaningless when the frequency display is unstable.

For measurements on **frequency inverters** we recommend to utilize **Sync I**.

- 3W:** 3-Wattmeter configuration, averages and sums are computed from phase L1, L2, and L3.
- 2W:** 2-Wattmeter configuration averages and sums are computed from phase L1 and L2.

5.2.4 SELECTING MEASUREMENT TIME AND SPECIAL FUNCTIONS

The fifth annunciator from the top of the side menu displays the selected minimum signal acquisition time or one of the special functions available in your instrument. Move the cursor to this annunciator and press **SET**. Depending on the instrument version one of the following pull-down menu will be displayed:

>250ms	>250ms	>250m
>500ms	>500ms	>500ms
>1s	>1s	>1s
>2s	>2s	>2s
>4s	>4s	>4s
	Logging	Logging
		IEC-3-2

Now move the cursor to the desired time or function and press **SET** to return to the side menu. Before you select a special function you should apply a synchronization signal. This can be a current or a voltage on phase L1.

The basic measurement process for measurement times >250ms, ..., 4s and for the special functions is described below:

>250ms, ..., 4s: The selected time sets the duration of signal data acquisition for one measurement interval. The measurement is synchronized to the zero crossing of either current (Sync I), or voltage (Sync U). Measurements are thus taken over full periods and result in stable readings for signal frequencies down to 2Hz. In case the selected time interval has expired but the signal period has not reached its end the measurement time is extended to the end of the signal period.

In the selected measurement time all raw data in a three phase system are collected, and are made available for display or for data transfer to a PC via interface. This process runs continuously.

IEC-3-2, Logging: To select one of the special functions move the cursor in the pull-down menu to the particular position and press **SET**.

For the two special functions a synchronization signal must be applied. Without synchronization the display number - and graphics field may not be updated in regular intervals anymore. Synchronization to current or voltage of phase L1 is possible. More information on the two special functions is given in section 5.2.5.

5.2.5 SELECTING IEC1000-3-2, OR LOGGING

Before you select the special function **IEC-3-2** you should apply line current or line voltage to phase L1 and select **Sync I** or **Sync U** accordingly. Without a synchronization signal the display update may stop.

A. IEC-3-2

This special function measures line current harmonics according to **IEC1000-3-2**. Sixteen periods are used to calculate current harmonics h01 to h63 of one phase or all three phases from the same set of measurements. Voltage and power harmonics are available as well.

Window Operating Software supports **IEC1000-3-2** measurements. An RS-232 interface, Option 01 or Option 02 is required. With the operating software you can select the range of harmonics and you can select a data file, which contains the limits of the current harmonics. Running the software the actual measurements are compared on-line against the limits and are indicated either in a list or in a bar graph. Measurements can be printed.

B. LOGGING

The data logging function is used to measure transient behavior of single- and three phase systems. This can be the start-up of any electromechanical system, or the no-load to load condition of a rotating device. Using data logging longtime monitoring of systems up to 1 year is possible too. Manual ranging must be used at all times.

Before selecting the logging function you should apply a synchronization signal to phase L1 (current or voltage).

Once you have selected the Logging function the Power Analyzer updates the display in a normal fashion every 500ms. It actually waits for the interface trigger indicating the start of the transient process. Upon this start signal the display update is stopped. The programmed numbers of measurement sets are sent on-line to the PC. When finished the Power Analyzer resumes regular display update and is ready again for the next start signal.

A data set contains 3 measurement values using a single phase instrument and 9 measurement values using a three phase instrument. Display fields 0, 1, and 2 determine the measurement values sent to the PC (field 0 is top left, field 1 is top right, field 2 is second row left). Field 0 data are transmitted first (phase L1, L2, and L3), field 1 data are transmitted second (phase L1, L2, and L3), and field 2 data are transmitted last (phase L1, L2, and L3). In display fields 0, 1, and 2 any measurement quantity is permitted except fft-values, THD1, THD2, and reactive power.

The allowable frequency range of the synchronization signal is 5Hz to 400Hz and can vary during the logging process. Always there must be sufficient time to transmit a data set to the PC and be ready again for the next data set (150ms per data set at 9600 Baud). Cycles must be set such that this minimum time is never violated. Example 5.1 shows how to use the Logging function.

In every logging pass the maximum values of the three quantities displayed in field 0, 1, and 2 are stored and can be viewed when HOLD is entered (logging and display mode L1, L2, L3 must be selected).

Setup for Logging

- **Synchronization:** The synchronization signal assures regular display updates every 500ms. To make use of the logging function an RS-232 interface must be installed in the Power Analyzer and the data logging software module must be installed on a Personal Computer.
- Place in the display **fields 0, 1, and 2** those measurement quantities you want to transfer to the PC (Field 0=top left, field 1 = top right, field 2 = second row, left no fft-values are permitted). Section 5.4 explains how to place values in the numeric fields.
- Select **Cycles** from the **SETUP** menu (Section 5.3.6). **Cycles** = 8 means that a new measurement set is generated every 8 periods. **Cycles** can be in the range 1 to 32767.
- Select **Logg N** from the SETUP menu (Section 5.3.6). **Logg N** = 100 means that 100 measurement sets are transmitted to the PC. **Logg N** can be set in the range 1 to 32767.
- The **duration t** of the data logging measurement is determined by
 $t = \text{period length} \times \text{cycles} \times \text{logg N}$
 For the above example at 50Hz line frequency $t = 20\text{ms} \times 8 \times 100 = 16 \text{ seconds}$.
- A **measurement set** consists of the quantities placed in display field 0, 1, and 2 for phase 1, phase 2, and phase 3; that is, 3 values for a single phase Power Analyzer and 9 values for a 3-phase Power Analyzer.
- The **synchronization** signal (Sync I, Sync U) for the logging function is an important matter. First, it keeps the Power Analyzer in a ready state to instantly start the data logging function when the start command has been received, and second, the synchronization is a fixed or variable time base to yield precise values. The frequency range of the synchronization signal is 5Hz to 400Hz.
- **Manual Ranging** for current and voltage must be used.
- **Logging Start:** The data transmission to the PC can be started by the trigger command *TRG via software.
 The software trigger command does not guarantee a precise start. During data transmission the display update is stopped and is resumed when transmission is finished.
- **Baud Rate:** To achieve the maximum data transmission speed of 9 values per 150ms (3 phase Power Analyzer synchronized to a 50Hz signal) the Baud rate of the Power Analyzer must be set to 9600 Baud. The Baud rate of the software mask (front panel) should then be set to 9600 Baud. This setting must be done prior to any communication between PC and instrument.
 At 9600 Baud you can expect 9 values per 150ms. In this case you would have to set Cycles to 8 for a 50Hz synchronization signal.

Example 5.1: Investigate the transient behaviour of an induction motor at start-up. Motor data: delta connection, 230V/50Hz, current = 20A. RMS current, power, and power factor versus time needs to be measured in time intervals of 160ms (8 periods at 50Hz), measurement duration 8 seconds.

- STEP 1: Connect the Power Analyzer as shown in Figure 4.4. Use the 50A current input. Select manual ranging, 300V range, and 100A range (the maximum start-up current is not known).
- STEP 2: Set display fields as follows: rms current in field 0, power in field 1, and power factor in field 2.
- STEP 3: Go to the **SETUP**-menu and set **Cycles** to 8, this implies a measurement set every 8 cycles = 160ms. Set **Logg N** to $8\text{s}/0.16\text{s} = 50$; this implies a measurement duration of $20\text{ms} \times 8 \times 50 = 8\text{s}$. Further-more, set Baud rate to 9600 to achieve the necessary data transmission speed.
- STEP 4: Apply voltage to the Power Analyzer input. Select synchronization to voltage (phase L1), and select the special function "Logging". The display is now updated two times per second.
- STEP 5: Prepare on your Personal Computer the front panel for the logging function. Install a one-to-one connected RS-232 interface cable between PC and Power Analyzer.
 Follow the software instructions to setup the front panel properly. This setup repeats settings already described in steps 1, 2, and 3. Once you are familiar with the use of the logging function steps 1, 2, and 3 can directly be done via software with the exception of the Baud rate.
- STEP 6: Start the measurement and the motor simultaneously. Eight seconds later you have the data available in EXCEL as shown below. From the table you quickly find the peak current. If it is less than 40A you can select the 30A range for the next measurement instead of the 100A range (the 30A range tolerates 42Arms without loss of accuracy).

Irms L1	Irms L2	Irms L3	Power L1	Power L2	Power L3	PF L1	PF L2	PF L3
...	...							
...	...							

Alternatively, you could first start the logging function and start the motor a second later. If you do this you may have to increase the durations of the measurement by increasing Logg N via Software.

5.2.6 SELECTING VARIOUS DISPLAY MODES

Move the cursor to the sixth annunciator in the side menu and press **SET**. The pull-down menu **VIEW L1 / VIEW L2 / VIEW L3 / VIEWSUM / VIEWALL** presents five choices of possible display modes (available on 3-phase Power Analyzers only).

The **VIEW L1/L2/L3**-display-modes display numeric values in large size numbers combined with graphics of the selected phase.

The **VIEWSUM**-display-mode displays numeric values in large size numbers with graphics selectable from phase L1, L2, or L3. For power and associated values the total and for voltage- and current values the average of the 3-phase system is displayed (see section 3 for definitions).

The **VIEWALL**-display-mode displays up to 40 numeric values of the 3-phase system. The screen is split in four columns for L1-, L2-, L3-, and sum values. In this display mode no graphics area is available.

5.2.7 SELECTING THE GRAPHICS IN THE VIEWSUM-DISPLAY-MODE

If you have selected the **VIEWSUM**-display-mode (section 5.3.6) you can select in the graphics area data from phase L1, L2, or L3. An annunciator indicates the display mode in the side menu (seventh from top). Move the cursor to this position and press **SET**; the pull-down menu **GRAPHL1 / GRAPHL2 / GRAPHL3** appears from which you can select graphics from L1, L2, or L3.

5.3 OPERATIONS CONTROLLED BY THE BOTTOM LINE MENUS

This section describes the use of the main menu. The main menu is displayed when the cursor is placed in the side menu or in one of the numeric fields. The keys **M1, M2, M3, M4, M5, M6** are used to select a function. Pressing a key pointing to an empty menu field has no effect.

5.3.1 MAIN MENUS

Keys **M1** through **M6** select the main menus | **HOLD** | **AC+DC** | **PRINT** | **SPLIT** | **VIEW** | **SETUP** |. The menu |**AC+DC**| is only present when the cursor is in the numeric display field pointing at a quantity that can have a DC component.

5.3.2 MAIN MENU <HOLD>

Press key **M1** to enter the display hold state. The **HOLD** annunciator at left bottom indicates it. Numeric values and graphics are held while the measurement process goes on. This is particularly useful for the energy measurement. Press key **M1** again to return to the **RUN** state.

5.3.3 MAIN MENU <AC+DC>

The menu |**AC+DC**| is selected by **M2** and is used to include or exclude DC components in a measured quantity. RMS- and power values offer the choice of AC- or AC+DC-coupling. Therefore, move the cursor to an RMS- or power value in the numeric field to activate the **AC+DC** menu. Simultaneously, a status indicator AC or DC above the current deflection bar graph indicates whether the value includes DC components or not. Key **M2** toggles the status indicator AC/DC. This way DC components can individually be included or not.

NOTE: Selecting a value to include DC it will be included in phase L1, L2, and L3.

5.3.4 MAIN MENU <SPLIT>

The **SPLIT** menu lets you divide the display into a graphics area and a numeric field area. On pressing key **M4** a sub-menu | **ESC** | **EXP** | **RED** | | | | appears. Pressing **M2** = **EXP** will increase the graphics area by 20 %, pressing **M3** = **RED** will decrease the graphics area by 20 % and increase the numeric area by 20 %. When you have made your choice press **M1** = **ESC** to return to the main menu. With the **SPLIT** menu you can place 0, 2, 4, 6, 8, or 10 numeric values on the screen (display modes L1, L2, L3, SUM). The **VIEWALL** display mode lets you view 40 values maximum.

5.3.5 MAIN MENU <VIEW>

The menu **VIEW** lets you change the graphics in the graphics area of the display. Press key **M5** to display the sub-menu | **ESC** | **FFT_i** | **FFT_u** | **FFT_p** | **i (t)** | **u (t)** |. The bar graphs FFT_i, FFT_u, and FFT_p of current, voltage, and power, and the waveforms i (t), and u (t) of current and voltage are available. Press one of the keys **M2, M3, M4, M5, or M6** to select the desired graphics; with key **M1** you return to the main menu. The number of harmonics displayed in the bar graph depends on the fundamental frequency range of the signal as shown in the table below.

Fundamental frequency	Harmonics	Waveform
4Hz-400Hz	64	1 period
400Hz-3kHz	8	8 periods
3kHz-13kHz	1	
DC-4Hz, >13kHz		

5.3.6 MAIN MENU <SETUP>

If you want to change interface parameters, instrument start-up configuration, or other parameters press key **M6**. The setup display screen is presented. It is split into two columns. In the left hand side you find from top to bottom current scaling factors, voltage-scaling factors, setup save number, setup recall number, **Cycles**, **Logg N** and analog input **A0** scaling factor. In the second column the RS-232 interface parameters are listed. To change a number or setting move the cursor to the desired position and press **SET**. Integers or settings are incremented by pressing **SET**, and numbers with exponents are incremented digit by digit by pressing **UP↑** or **DOWN↓**. To leave the **SETUP** screen press **ESC=M1**.

The SETUP screen is shown below:

Scal I1	+1.00000e+00	Baudrate	9600
Scal U1	+1.00000e+00	Parity	None
Setup	Save No 00	End mode	CR+LF
Setup	Recall No 00	Protocol	None
Logg N	+1.00000e02	GPIB addr	n/a
Cycles	+5.00000e+00		
Scal A0	+1.00000e+00		

Scal I1: The current input scaling is a multiplication factor for the current inputs. If you use a current transformer whose output is 0.001 of the primary current actual current- and power display is obtained if you set the scaling factor to 1000. All three phase currents are multiplied by the same factor. Future software versions (v1.1R0) will permit individual scaling for every phase (scaling I1, scaling I2, scaling I3). To enter a scaling factor via front panel move the cursor to **Scale I** and press **SET**. The cursor is now pointing at the sign of the scaling factor; with **UP↑** or **DOWN↓** the sign can be changed. Pressing **RIGHT→** the cursor can be moved to the first digit. Pressing **UP↑**

the digit is incremented and pressing **DOWN↓** it is decremented. Any number can be entered this way and is concluded by pressing **SET**.

If you have an instrument with software version v1.1R0 or higher (delivered May 2002 or later) you can also enter a scaling factor for phase 2 and 3. Press **SET** again to edit the scaling factor phase 2 and proceed as described above, then press **SET** once more to edit the scaling factor of phase 3.

Scal U1: The voltage input scaling is a multiplication factor for the voltage inputs. For high voltages >1000V an external voltage divider, for example 1/10, can be used. To obtain actual voltage and power readings the voltage scaling factor is set to 10. All three phases are using the same scaling factor. Future software versions (v1.1R0) will use individual scaling factors for every phase. To enter a scaling of 10 move the cursor to **Scal U1** and press **SET**. Now move the cursor to the last digit of the exponent, press **UP↑** once to increment the exponent by 1, and press **SET** to finish and store the factor.

If you have an instrument with software version v1.1R0 or higher (delivered May 2002 or later) you can also enter a scaling factor for phase 2 and 3. Press **SET** again to edit the scaling factor phase 2 and proceed as described above, then press **SET** once more to edit the scaling factor of phase 3.

Setup Save No: "Setup Save No" is used to store your personal instrument settings at 12 different memory locations. This is how you proceed. Configure the display of the Power Analyzer, set all parameters in the side menu and all parameters in the **SETUP** menu.

Caution: You must disconnect all voltage- and current input signals from the inputs before proceeding with the next steps.

To save the instrument settings move the cursor to "**Setup Save No**". Every time you press **SET** the **Setup Save No** is incremented by 1. When you have reached the desired number press **M1 = ESC** to return to the main menu.

NOTE: To actually save the setting you must increment the **Setup Save No** at least once before pressing **M1 = ESC**. If you do not, the setting will not be saved!

A stored setting saves all parameters of the **SETUP** menu, of the side menu, and of the main menu.

Logg N, Cycles: These parameters are used in conjunction with the data logging function and the dynamic torque measurement. They determine the duration of the measurement as follows:

Duration = period length of the synchronization signal x Cycles x Logg N.

The period length is given by the synchronization signal used in the measurement. "Cycles" sets the number of periods, which are used to compute one measurement set. **Logg N** determines the number of measurement sets transferred via interface to the personal computer and to the analog outputs.

To change **Logg N** or **Cycles** move the cursor to the desired position, press **SET** and proceed as described in **Scal I1** for entering an exponential number.

RS-232 Interface Parameters: To change a parameter you must move the cursor to the desired position. Press **SET** to either toggle the parameter or incremented it to the next value. The following baud rates are available: 4800, 9600, and 19200. Higher Baud rates are available but should not be used.

5.4 OPERATIONS CONTROLLED BY THE NUMERIC DISPLAY FIELD

This section describes how you can place measurement functions in the numeric fields and how you select associated parameters.

5.4.1 THE MEASUREMENT FUNCTION SELECTION TABLE

This is how you can visualize the measurement function table. Move the cursor away from the side menu to one of the numeric display fields, say field 0 and press **SET**. The measurement function selection table is presented from which you can choose a new function to be displayed in field 0 (remember field 0 is at top left) and field 9 at bottom right).

Current	RMS	Mean		CF	FFT
	Min	Max	Peak	THD2	THD1
Voltage	RMS	Mean	Vl _{tl}	CF	FFT
	Min	Max	Peak	THD2	THD1
Power	Activ	VA _{app}	VA _{area}	Energy	FFT
P-Mech	Input	Output	Torque	Speed	Et/SL
Other	Freq	PFact		Z	∠Z

Measurement Function Selection Table

Depending on instrument version not all functions may be displayed.

Please refer to section 3 for definitions of the measurement functions. With the cursor you can reach any position in the function selection table.

This implies that in the display fields 0 to 9 any measurement function can be displayed. Simply move the cursor to the desired position in the function selection table, press **SET** to return to the main display. The cursor sits now on the revised display field displaying the selected measurement function. In a last step you can now modify the attributes associated with the selected measurement function. The attributes such as AC, AC+DC, h01, or p08 are displayed in the side menu and can be modified by means of a bottom line menu. These procedures are described in sections 5.4.2 through 5.4.14.

5.4.2 SELECTING RMS-VALUES

RMS values apply to phase currents, phase voltages, and line-to-line voltages. An rms value contains DC-components if you set the attribute to DC, or it contains AC components only if you set the attribute to AC. RMS values always contain all harmonics within the frequency range of the instrument. It is acceptable to display the rms value in one display field with DC-component and in another without DC-component. To achieve this move the cursor to the desired display field and press **SET**. The function selection table is presented. Move the cursor to **RMS** and press **SET** again to return to the main display. The cursor points to the revised display field. The annunciator DC or AC in the side menu can be toggled with menu key **M2** (menu AC+DC) to the required coupling (including or excluding DC component).

NOTE: In the VIEWALL-display mode, display field 0 corresponds to display line 0 and display field 9 corresponds to display line 9. The placement of measurement functions and the selection of attributes follow the same rules described above.

5.4.3 SELECTING MIN, MAX, PEAK, AND CF

Min, Max, Peak (peak-to-peak), and CF apply to phase currents and phase voltages. All values are DC-coupled and therefore have the DC attribute only. To select one of these quantities move the cursor to the display field, press **SET** and now move the cursor in the measurement function selection table to the required function. To finish press **SET** and return to the main display mode. The DC attribute is shown in the side menu.

5.4.4 SELECTING POWER VALUES

Power values are: active power (or just power), apparent power, and reactive power. All three values include harmonics of the whole spectrum up to 300kHz.

DC components can be accounted for when selecting the DC attribute (AC+DC-coupled). Selecting the AC attribute DC components of the power values is disregarded.

The procedure for displaying power values is the same as described for rms values.

5.4.5 SELECTING AND RESETTING ENERGY VALUES

The two energy values, active energy and apparent energy, are the summation of power and apparent power over time. Values for every phase and their total are determined from start (after reset) to the end of measurement. The summation goes on even when the display is in **HOLD**.

Although, in the measurement function selection table there is only one energy label, it is possible to select both quantities, active- and apparent energy. Let us view active energy in display field 0 and apparent energy in display field 1. Move the cursor to field 0 and press **SET**. Move the cursor to **Energ** in the function selection table and press **SET** again to return to the main display. The attribute **ACT** in the side menu indicates that you have selected active energy, which is what we wanted. Now move the cursor to display field 1, press **SET**, then move the cursor to **Energ** (Energy) and press **SET** again. Back in the main display mode the attribute **ACT** shows that we have selected active energy. Using the bottom line menu | **HOLD** | **ACT** | **APP** | | **RESET** | |. **ACT** can be changed to **APP** by pressing menu key **M3**. Display field 1 now displays apparent energy.

To start an energy measurement you probably want to reset the energy values. For this purpose move the cursor to an energy value (display field 0 or 1) and press menu key **M5** (RESET) to start energy computation.

5.4.6 SELECTING MECHANICAL VALUES

Six mechanical quantities are available: input power, output power, torque, speed, efficiency, and slip. Number of poles of an electrical motor can be entered, internal or external speed measurement can be selected, and motor loss in no-load condition can be stored. The procedure for displaying mechanical values follows the same rules as described for power and energy. No provision is made for external speed measurement. Use internal speed measurement only.

Input: Input power to an electromechanical device corresponds to total electrical power applied and is expressed in **Nm/s**. It can be displayed in any display field 0 through 9 as described for energy in section 5.4.5.

You can store special input power values such as idle power at a given speed. To store a values move the cursor to input power, A bottom line menu appears:

| **HOLD** | **STORE** | **RESET** | | | |

Press key **M2** to store a values, press key **M3** to reset a stored value.

Output: This quantity in **Nm/s** is equal mechanical input power minus power loss in the electromechanical device. Output power, therefore, corresponds to power applied to the mechanical load applied to the device. Proceed as follows to obtain output power. Run the electromechanical device at no load condition and store input power as described above. Now run the electromechanical device with the load applied. Output power is a measure of power applied to the mechanical load.

NOTE 1: If you have not stored any input power value (power loss), or if you have reset stored input power then output power is equal input power. In this case you are assuming that power loss of the electromechanical device is negligible.

NOTE 2: If you save an instrument setting in nonvolatile memory stored input power is saved and reloaded at start-up.

Torque: Torque computations use mechanical output power, number of poles, and internal (current or voltage) frequency. Prior to torque measurement you must set number of poles and internal speed measurement. To do this display torque and speed in a display field as follows:

To select torque and number of poles move the cursor to a display field 0 through 9. Press **SET** and move the cursor to **Torqu** and press **SET** again to return to the main display. The cursor points now to torque. The number of poles, e.g. P02, is displayed in the side menu. The number of poles can be incremented or decremented using the bottom line menu | **HOLD** | | **N-1** | **N+1** | | |.

To select internal speed move the cursor to a display field 0 through 9. Press **SET** and move the cursor to **Speed** and press **SET** again to return to the main display. The cursor points now to speed in **rpm** (revolutions per minute). The side menu shows **INT** or **EXT**. Using the bottom line menu | **HOLD** | **INTERN** | **EXTERN** | | | | internal speed measurement is selected.

Torque computation uses mechanical output power. Therefore, the user can either display average torque in the air gap of the electromechanical device if stored input power is reset to zero or he can display average torque developed at the mechanical load if power loss of the device is stored and is used in torque calculation.

Speed: Speed in revolutions per minute (rpm) is derived from internal current- or voltage frequency. Speed calculation requires the number of poles of the rotating device. Therefore, the number of poles must be set as described above in section **Torque**. To display speed you move the cursor to a display field 0 through 9 and press **SET**. Now move the cursor in the measurement function selection table to **Speed** and press **SET** again. Back in the main display mode the cursor points to speed in **rpm**. The side menu display **INT** indicating that you have selected internal speed measurement. By means of the bottom line menu | **HOLD** | **INTERN** | **EXTERN** | | | , using key **M2**, internal speed measurement can be selected.

If you select external speed measurement a frequency input from an external transducer at analog input 0 (A00) is expected. This analog input is not available for this Power Analyzer.

Et/SL: **Eta = efficiency / SL = Slip** are two additional quantities of interest for electromechanical device testing. Please refer to section 3 for definitions. Efficiency makes sense only if you have stored input power required at no load condition. Please refer to section **Input** for more information. Slip applies to induction motors only. It requires an external speed transducer whose output frequency is applied to analog input A0 (not available for this Power Analyzer).

To display efficiency and/or slip move the cursor to a display field 0 through 9 and press **SET**. Now move the cursor in the measurement function selection table to **Et/SL** and press **SET** again. Back in the main display mode the cursor points to **Eta** indicated in the side menu by **ETA**.

At the same time the bottom line menu displays | **HOLD** | **ETA** | **SLIP** | | | | from which the desired quantity can be chosen.

5.4.7 SELECTING FREQUENCY

Selecting frequency is straightforward. Move the cursor to a display field, press **SET** and move the cursor to **Freq** in the measurement function selection table and press **SET** again.

The source of measurement is determined by the selected synchronization **Sync I**, **Sync U**, or **EXT**. **Sync I** implies frequency measurement and FFT (Fast Fourier Transform) is synchronized to the fundamental frequency of phase current L1, and **Sync U** implies synchronization to phase voltage L1 (EXT is not available for this Power Analyzer).

FFT- and their derived values are available only when the frequency display is stable. Built in low pass filters enhance the capabilities to synchronize to the fundamental signal frequency.

For practically all electronically driven inductive loads synchronization to current is the better choice.

NOTE: To perform measurements in a single phase system using a three phase Power Analyzer we suggest applying signals to phase L1. This way synchronization to voltage or current of phase L1 is possible.

5.4.8 SELECTING POWER FACTOR (PF)

The power factor is displayed by selecting **PFact** in the measurement function selection table. The power factor is the ratio of power divided by apparent power. In many situations using modern power electronics the power factor appears to be too small. Why?

Power electronics most often generates a more or less sinusoidal current using a train of voltage pulses. The broadband rms voltage is larger than an equivalent sinusoidal voltage that would cause the same current to flow. As a consequence apparent power increases in case of the pulsed voltage and power factor decreases and is, after all, not a meaningful quantity to use. Instead of power factor use the phase angle between the fundamental waveforms of voltage and current (section 5.4.12 Selecting Phase Angle). Cos (phase angle) corresponds to the power factor of the classical power line frequency technique.

5.4.9 SELECTING THD (TOTAL HARMONIC DISTORTION)

The first software version v1.0R0 uses one **THD = THD1** (see section 3 for definition). Later software versions (v1.1R0) will contain a second definition **THD2**. To display one of these quantities enter the measurement function selection table. Move the cursor to THD1 or THD2 and press **SET**. The attribute of both, THD1 and THD2, is DC-coupling.

THD1 is more suitable to use on electronically switched power electronics such as frequency inverters. Using **THD2** on frequency inverters would yield a very small THD of less than 0.01 (1 %). But this is not true, particularly not for voltage, which has a high content of distortion over a wide frequency range.

THD2 is more suitable for measurements on the power line, which has a low content of distortion with the main contribution of THD2 at harmonics of the fundamental frequency. **THD2** is available in the frequency range 4Hz to 380Hz.

5.4.10 SELECTING FFT VALUES, HARMONICS 1-63

FFT-values (Fast Fourier Transform) are available for 3 phase currents, 3 phase voltages, and 3-phase power. All values are computed simultaneously. You can display up to 30 FFT values if you select the **VIEWALL** display mode.

Let us display harmonics 1, 3, and 5 of current in display fields 0, 1, and 2. Move the cursor to display field 0 and press **SET**. From the measurement function selection table select FFT of current and press SET once more to return to the main display. Because the cursor points to display field 0 the attribute h01 of the FFT-value is shown in the side menu. The bottom line menu | **HOLD** | **N-10** | **N-1** | **N+1** | **N+10** | lets you increment or decrement the harmonic number by 1 or by 10. Let us place harmonic h01 in display field 0. Similarly, we place harmonic 3 in display field 1, this time we increment the harmonic number to h03 using the bottom line menu. Finally, we place harmonic number 5 in display field 2 and increment the harmonic attribute to h05. The fundamental of current, voltage, and power are important quantities when working with inverters.

Range of fundamental frequency 4Hz-380Hz:	available Harmonics 0-63
Range of fundamental frequency 380 Hz- 3kHz:	available Harmonics 0-7
Range of fundamental frequency 3kHz- 10kHz:	available Harmonics 0-1

5.4.11 SELECTING MAGNITUDE OF IMPEDANCE 1-63

Impedance is the ratio of voltage divided by current. It has a magnitude and an associated phase. The phase is nothing but the phase shift between voltage and current. When the signals contain harmonics an impedance for every harmonic can be determined.

Selecting | **Z** | from the measurement function selection table displays the magnitude of impedance. | **Z** | for every harmonic 1-63 can be selected by incrementing the attribute h01 up to h63 using the bottom line menu | **HOLD** | **N-10** | **N-1** | **N+1** | **N+10** | |.

5.4.12 SELECTING PHASE ANGLE OF HARMONIC 1-63

Phase angle between voltage and current of the fundamental frequency is a valuable quantity when working with frequency inverters. In section 5.4.8 is explained why the power factor is a poor quantity to use on signals with high distortion. Because power is transferred to a motor mainly at the fundamental waveform, phase angle is a much better function to characterize the system. Cosine of the phase angle of the fundamental is very close to power factor used in conventional power line systems.

Selecting | **Z** | from the measurement function selection table displays phase angle of harmonics 1-63. Use the bottom line menu | **HOLD** | **N-10** | **N-1** | **N+1** | **N+10** | | to select the desired harmonic h01, h03, ..., h63.

6. OPERATING THE POWER ANALYZER USING THE COMPUTER INTERFACE

6.1 INTRODUCTION

The Power Analyzer can be operated from a host by sending commands to it through a computer interface on the rear panel. Section 6 describes how to set up, configure, and operate the Power Analyzer via the RS-232.

6.2 LOCAL AND REMOTE OPERATIONS

When the Power Analyzer is operated from a host then it is operated „remotely“, when operated from its front panel the Power Analyzer is operated „locally“. The Power Analyzer is no longer controllable from the front panel when via interface the **Local Lockout** state has been enabled.

6.3 RS-232 COMPUTER INTERFACE

Your Power Analyzer can be equipped without interface, or with RS-232 interface (Option 01 and 02). You can check on the rear panel which options you have installed. You can operate several instruments in parallel if you install the required number of RS-232 ports on your computer.

6.4 SETTING INTERFACE PARAMETERS

The Power Analyzer sets the parameters at startup to the following default values:

Baud:	9600
Parity:	None
Terminator:	CR
Handshake:	None
IEEE-address:	n/a

Above parameters can be changed by entering the **SETUP** menu via the front panel or by sending commands through the computer interface.

In order for the Power Analyzer and the host to communicate through the interface the communication parameters of the Power Analyzer must match those of the host.

6.5 CABLING THE POWER ANALYZER TO A HOST

Turn Power Analyzer off. When cabling is complete turn power on again. The RS-232 interface on the Power Analyzer rear panel uses a DB-9 connector. Its pin out is given below.

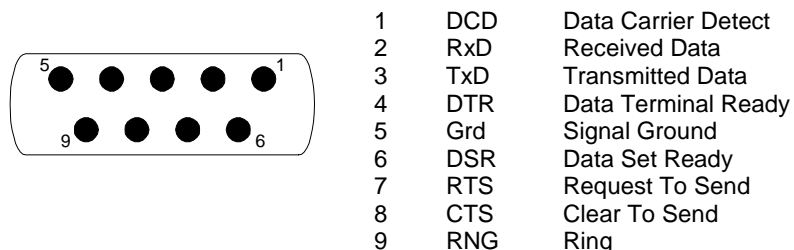

The RS-232 cable length should be less than 15m to make sure not to exceed the allowable (2000pF) cable capacitance.

NOTE: Use a standard one-to-one connected RS-232 interface cable to connect PC and Power Analyzer (RxD and TxD are not crossed).

6.6 HOW THE POWER ANALYZER PROCESSES INPUT

The Power Analyzer processes and executes valid input strings sent by the host. A **CR/LF** (carriage return/line feed) terminates an input string.

When the Power Analyzer receives input, it stores it in a 32 byte input buffer. As soon as the input terminators have been recognized the data in the buffer are processed.

The Power Analyzer accepts upper and lower case characters. If a command cannot be understood, or it was longer than 32 characters, which cannot be the case for correct commands, the command will be ignored and an error will be generated.

6.6.1 INPUT TERMINATOR

An input terminator is a character or command sent by the host identifying the end of a string. Any of these terminators will be recognized as „end of message“.

Valid terminators for the RS-232 interface are:

CR (Carriage Return), **LF** (Line Feed)
CRLF (Carriage Return / Line Feed), and
LFCR (Line Feed / Carriage Return)

6.6.2 SENDING COMMANDS TO THE POWER ANALYZER

Command	Action
VOLT:RMS:AC 1	AC-coupled rms voltage is displayed in display field 1 (fields are: 0 = top left, 1 = top right ... 9). The minimum required characters (upper case) are used.
voltage:rms:ac:?	Query form. To this command the Power Analyzer outputs (in scientific format) an alphanumeric string of the ac-coupled rms voltage. The maximum allowable characters in lower case are used.
CURR:SC1 1.000e0	Sets the phase 1 current scaling factor of the Power Analyzer to 1.
CURR:SC2?	Query form. The Power Analyzer returns the current scaling factor of phase 2 in scientific format.
CURR:FFT?	Query form. The Power Analyzer returns the harmonics of current in the range specified by the FORMAT:START/END command.

Commands can be sent in upper or lower case characters. The upper case letters in the command set table are the minimal string to be sent, the lower case letters are optional. No space is allowed except for the selector at the end of a command where a space is mandatory.

RULE 1: A terminator must close every command. The maximum length must not exceed 32 characters.

Rule 1 implies that sending a batch file to the Power Analyzer consisting of several commands requires a delay of up to 200ms between the commands.

This delay is particularly needed at start-up. When configuring the instrument, e.g. setting current input, current range, voltage range, measurement time, scaling factors, and configuring the display. If you send these commands without delays most likely only part of the commands are executed.

In the normal measurement process you send a query and wait for the response. You send the next query only if you have received data. Therefore, a delay is not required.

RULE 2: Read Power Analyzer's output only once for each query command. The output buffer is cleared after it has been read. This prevents previously read data from being read a second time by mistake. A device dependent error is generated. (Query commands are identified by the „?“ at its end).

RULE 3: Read query responses before sending an other command string.

If you send a query without removing the old message from the query before the old message gets lost. A device dependent error is generated.

6.6.3 HOW THE POWER ANALYZER PROCESSES OUTPUT

When the host sends a query command the Power Analyzer places an alphanumeric string into the output buffer. In case of the RS-232 interface, data are transmitted right away and are terminated with the set terminators (see RS232: Terminator command). The output from the Power Analyzer can be measurement data in scientific format. This can be a single string or, for a range of harmonics, 2 to 63 strings.

Query	Examples	Explanation
VOLT:RMS?	+ 1.0238e+01	Measured voltage 10.238V
POW:ACT?	- 1.8351e+00	Measured power -1.8351W
CURR:RMS?	+ 5.8975e-03	Measured current 5.8975mA
FORM:START 1		
FORM:END 5		Harmonic currents n = 1 to 5.
CURR:FFT?	+ 9.0000e+00 + 0.0000e+00 + 3.0000e+00 + 0.0000e+00 + 1.8000e+00	

The output data can also be a scaling factor, an instrument setting, a range indication, or an error number.

6.6.4 OPTIMIZING SPEED FOR DATA TRANSFER

The Power Analyzer is optimized for continuous data acquisition. Servicing the RS-232 interface has second priority. Therefore, you should use a Baud rate of 39000 Baud for the **Logging** – and **DynTorque** measurement functions. Lower Baud rates can be used but you will not attain the specified speed of 9 values per 20ms (Logging function using a 3-phase Power Analyzer).

For all other Power Analyzer operating modes the standard Baud rate of 9600 Baud is sufficient. For 3-phase Power Analyzers a special command is available to read all 3 phases values using one query. **Once you have sent FORM:PH ALL the 3-phase Power Analyzer will always return 3 values to every query, phase L1 value first, L2 value second, and L3 value third.**

6.7 OPERATING SEVERAL INSTRUMENTS ON RS-232 FROM ONE COMPUTER

Sometimes it is desirable to control more than one instrument from the same computer. To do this you must have additional RS-232 ports available or you must install additional RS-232 ports.

You have now several options: either you write your own operating software using one of the available design software implementing as many RS-232 as needed, or, if you use more than one Power Analyzer, open windows for all Power Analyzers and operate them in parallel.

6.7.1 STATUS REGISTER DEFINITION

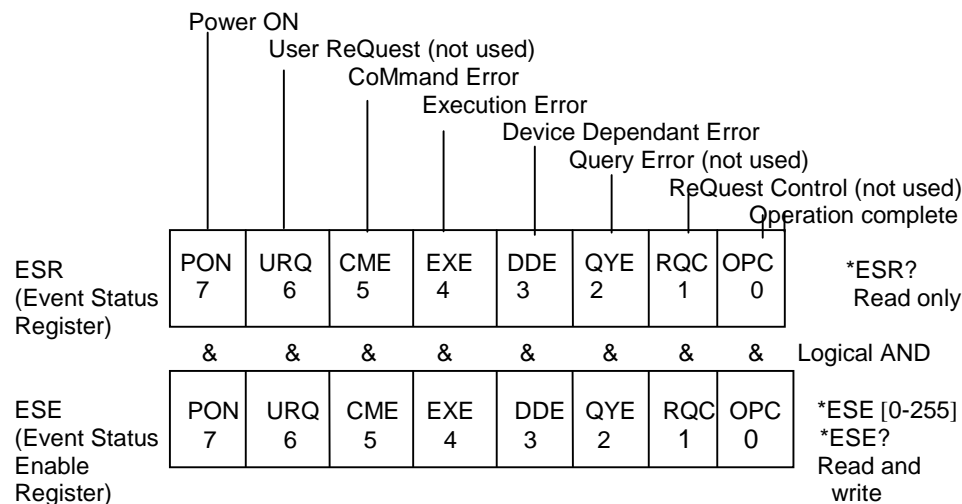

6.8 COMPUTER INTERFACE COMMAND SET

The following table lists the RS-232 commands. A parameter that must be supplied by the user is enclosed in angle brackets <parameter>. Commands can be sent in upper case or lower case.

The following conventions are used:

<F> = Field selector; it is an integer 0 to 9 used to select the display field on which a value must be displayed. Field 0 is top left, 1 is top right, ... field 9 is bottom right.

<R> = Scientific formatted real number, e.g. +1.0e1.

<N> = Signed integer number, e.g. +1024.

Query commands are terminated with „?“ and do not contain a <parameter>.

That part of the command that is written in capital letters is mandatory. The lower case letters are optional. We suggest to use the minimum number of characters required.

*** Command only available on three phase instrument.

COMMAND

DESCRIPTION

VOLTage:RMS <F>	Query or set field for DC coupled RMS voltage
:AC <F>	Query or set field for AC coupled RMS voltage
:MEAN <F>	Query or set field for arithmetic DC voltage
:MIN <F>	Query or set field for negative peak voltage
:MAX <F>	Query or set field for positive peak voltage
:PEAK <F>	Query or set field for peak to peak voltage
:LTL <F>	Query or set field for line-to-line voltage
:FFT <F>:G	Set the field (0,1,...,9) for voltage harmonic previously selected by the FORMat:START command. Use the G argument instead of <F> to display FFT(u) in the display graphic zone.
:FFT?	Query all voltage harmonics in the range specified by the FORMat:StArt and FORMat:END commands.
:CREST <F>	Query or set field for voltage crest factor
:CURVE	Query or set display U_r , U_s , U_T in the display graphic zone previously selected by FORMat:PHase L1/L2/L3. Default U_s . To query curve a measurement time of at least 500ms must be selected.
:Scale <R>	Query or set voltage scaling factor (v1.0R0)
:SC1 <R>	Query or set voltage scaling factor phase 1 (v1.1R0)
:SC2 <R>	Query or set voltage scaling factor phase 2 (v1.1R0)
:SC3 <R>	Query or set voltage scaling factor phase 3 (v1.1R0)
:THD <F>	Query or set field for Total Harmonic Distortion v1.1R0
:THD1 <F>	Query or set field for Total Harmonic Distortion 1 v1.1R0
:THD2 <F>	Query or set field for Total Harmonic Distortion 2 v1.1R0
CURRent:RMS <F>	Query or set field for DC coupled RMS current
:AC <F>	Query or set field for AC coupled RMS current
:RECT <F>	Query or set field for rectified mean current Transformer version only.
:MEAN <F>	Query or set field for DC current
:MIN <F>	Query or set field for negative peak current
:MAX <F>	Query or set field for positive peak current
:PEAK <F>	Query or set field for peak to peak current
:FFT <F>:G	Set the field (0,1,...,9) for current harmonic previously selected by the FORMat:START command. Use the G argument instead of <F> to display the FFT(i) in the display graphic zone.
:FFT?	Query all current harmonics in the range specified by the FORMat:START and FORMat:END commands.
:CREST <F>	Query or set field for current crest factor
:CURVE	Query or set display i_r , i_s , i_T in the display graphic zone previously selected by FORMat:PHase L1/L2/L3. Default i_s . To query curve a measurement time of at least 500ms must be selected.

:Scale <R>	Query or write current scaling factor (v1.0R0)
:SC1 <R>	Query or set current scaling factor phase 1 (v1.1R0)
:SC2 <R>	Query or set current scaling factor phase 2 (v1.1R0)
:SC3 <R>	Query or set current scaling factor phase 3 (v1.1R0)
:THD <F>	Query or set field for Total Harmonic Distortion
:THD1 <F>	For future use. Query or set field
:THD2 <F>	for Total Harmonic Distortion 1 and 2.
POWER:ACTIVE <F>	Query or set field DC coupled power in Watt.
:AC <F>	Query or set field AC coupled power in Watt.
:APPARENT <F>	Query or set field DC coupled apparent power.
:AC <F>	Query or set field AC coupled apparent power.
:REACTIVE <F>	Query or set field DC coupled reactive power.
:AC <F>	Query or set field AC coupled reactive power.
:FFT <F>:G	Set the field (0,1,...,9) for the power harmonic previously selected by the FORMat:START and FORMat:END command. Use the G argument instead of <F> to display FFT(p) in the display graphic zone.
:FFT?	Query all power harmonics in the range specified by the FORMat:StArT and FORMat:ENd commands.
:FACTOR <F>	Query or set the field for the DC coupled power factor
:AC <F>	Query or set the field for the AC coupled power factor
ENERGY:ACTIVE <F>	Query or set field of energy (long time integration)
:APPARENT <F>	Query or set field of apparent energy (long time integration)
:RESET	No query form, resets all energy values
MECANIC:INPUT <F>	Query or set field for DC coupled power input in Nm/s.
:OUTPUT <F>	Query or set field for DC coupled power output in Nm/s.
:TORQUE <F>	Query or set field for DC coupled torque in Nm.
:SPEED <F>	Query or set field for speed.
:ETA <F>	Query or set field for efficiency.
:SLIP <F>	Query or set field for slip.
:POLE <N>	Query or set number of poles 2 ... 32.
:SPIE <N>	Query or set speed internal/external N=0=internal, N=1=external.
:STORE	Store mechanical input power.
:RESET	Reset stored input power.
FREQUENCY <F>	Query or set field of current, voltage, or external signal frequency. Depends on synchronization.

IMPedance:MAGNitude <F>	Set the field for harmonic impedance previously selected by the FORMat:START command.
:MAGNitude?	Query all harmonic impedances in the range specified by the FORMat:START and FORMat:END commands.
:ANGLE <F>	Set the field for harmonic phase angle previously selected by the FORMat:START command.
:ANGLE?	Query all harmonic phase angles in the range specified by the FORMat:START and FORMat:END commands.

ACQUIRE:RANGE:VOLTage	Auto	
	1	Query or set voltage range.
	3	Examples:
	10	ACQ:RAN:VOLT AUTO Voltage in autoranging.
	30	ACQ:RAN:VOLT 300 Selects 300V range.
	100	
	300	
	1000	

ACQUIRE:RANGE:CURRENT	Auto			Query or set current input range
	100M	1	60M	(the valid option column is fixed
	300M	3	200M	by the active input, IN3, IN50,
	1M	10	600M	Clamp.
	3M	30	2	
	10M	100	6	

:INPUT	IN3	Query or set the current input or the clamp input.
	IN 50	
	Clamp	

:SYNChro	VOLTage	Query or set instrument synchronization mode,
	CURRent	Synchronizes to phase 1 or external signal.
	EXTeRne	Always defaults to 3W-configuration.

:APERture	250M	Query or set minimal averaging time, or special
	500M	measurement functions data logging, dynamic
	1	torque, or IEC1000-3-2 testing.
	2	
	4	Example: ACQ:APER LOG
	LOG	
	DYT	
	IEC	

:Hold	Run	Query or set acquisition subsystem.
	Stop	Display data are held.
:QUALity?		Query overload and underload of current and voltage
		inputs. An integer is returned. The integer indicates
		the state during the previous query
		(VOLT:,CURR:,POW:,EN:, or FREQ:). For more
		details refer to overload and underload register
		definition.

DISplay:FORMat [0..5]		Query or set the number of numeric fields on the panel.	:TERMinator CR LF CRLf	Query or set command terminating characters.
DISplay:Mode?	***	Query or select display mode. View L1, View L2, View L3, View Sum, and View ALL.	:HANDshakes None Xon	Query or set handshake mode
FORMat:START <N>		Query or set the range for data array transfer	*ESE [0..255]	Query or set the Event Status Enable register
:END <N>		Range of N for harmonic values is 1 to 63.	*ESR?	Query the Event Status Register (IEEE-488 only)
:LOGN <R>		Range of N for analog inputs is 0-9. The range of R for LOGN is: 1 to 32767	*RST	Resets instrument
:CYCLES <R>		The range of R of CYCLES is: 1 to 32767	*OPC?	Returns 1 if no measurement is pending.
FORMat:PHase?	***	Query or select phase for data transfers such as: VOLT:RMS?	*TST?	Performs self test, returns zero if successful
L1		If ALL is selected 3 values (phase L1 first) are returned to a query such as VOLT:RMS? ALL has to be sent once only.	*WAI	Suspends command execution until previous commands are complete.
L2			*TRG	Initiates a new measurement run if the Power Analyzer is set to Logging.
L3			*IDN?	Returns identification string in form:<Vendor, Model, Serial-Number, Firmware version>.
ALL			ERRor?	Query the last error code
AINPort <F>		Set display field for analog input port previously selected by the FORMat:START/END command.		
AINPort?		Query all analog input port values identified by the FORMat:START/END command. Range of allowed ports is 0 to 9.		
AIN0Scale <R>		Query or set analog-input-0 scaling factor.		
VERsion?		Query form only. Returns software version		
LOCK		Locks the instrument's front panel controls. The query form returns YES or NO whether the controls are locked or not.		
UNLock		Unlock the instrument front panel controls.		
RS232?		Query form only, returns all settings. Output format is BAUD;PARITY;TERM;HAND		
RS232:BAUD	2400 4800 9600 19200	Query or set baud rate		
:PARITY	None Even Odd	Query or set parity mode		

ERROR CODES DEFINITIONS:

- 102 Syntax Error**
The command was not recognized. ESR bit 5 is set (CoMmand Error)
- 110 Command header error**
A command followed by '?' was sent were no query form is available. And conversely: no '?' followed a query form only command. ESR bit 5 is set (CoMmand Error).
- 111 Header separator error**
Attempted to descend the command hierarchy at a place where there wasn't any subcommand. ESR bit 5 is set (CoMmand Error).
- 140 Character data error**
A too long and/or senseless command has been sent to the instrument. ESR bit 5 is set (CoMmand Error).
- 222 Data Out Of Range**
The command argument is not allowed. ESR bit 4 is set (EXecution Error).
- 2204 Measurement error, Measurement underflow. ESR bit 4 is set (EXec. Err.).**
- 2207 Measurement error, Measurement overflows. ESR bit 4 is set (EXec. Err.)**
- 350 Queue overflow**
This occurs if a query command attempts to place a new message onto the instruments output queue but there was still an old message waiting on the queue. This results in information loss. '350' replace the query answer and ESR bit 3 is set (Device Dependant Error).
- 2200** Input signal over- and under. One or more current- or voltage inputs were in over- or under load during the last query (VOLT:;CURR:;POW:;EN:;FREQ:). ESR bit 4 is set.

Overload and under-load Register Definition

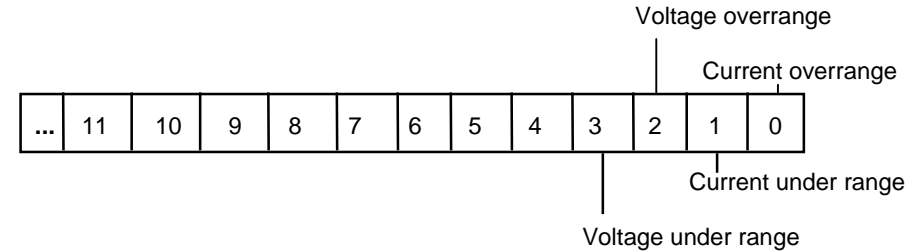

Current overrange: Current L1, or L2, or L3 is overrange.
Current under range: All 3 currents are under range

Voltage overrange: Voltage L1, or L2, or L3 is overrange.
Voltage under range: All 3 voltages are under range.

7. THE POWER ANALYZER OPTIONS

This section describes the capabilities and the use of the available options. Some of the functions described here are available only if you have an instrument version that supports this function.

7.1 OPTION 01: RS-232 INTERFACE, AND OPERATING SOFTWARE

The RS-232 interface on the Power Analyzer rear panel uses a DB-9 connector. The pin out of the connector is shown below.

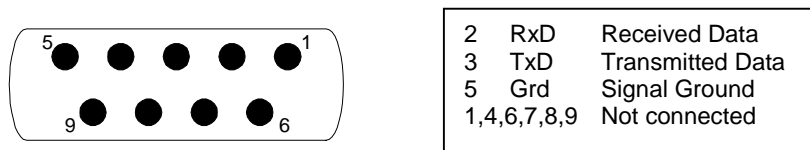

Figure 7.1 RS-232 connections for Option 01

7.1.1 RS-232 INTERFACE AND OPERATING SOFTWARE

The standard setting of the RS-232 Interface at Power Analyzer start-up is 9600 Baud and string terminators CR (carriage return) LF (line feed). We recommend using 9600 or 19200 Baud (higher Baud rates should not be used).

For data logging measurements 9600 or 19200 Baud should be used to achieve maximum speed on a 3-phase Power Analyzer of 9 values per 150ms.

The Windows Operating Software for option 01 contains modules to control the Power Analyzer, read data, and store data in EXCEL-compatible format. You can choose from the complete set of measurement quantities and you can select the number of quantities you want to display.

The software masks for the single phase and the 3-phase Power Analyzer look essentially the same and also have similar features. The 3-phase masks display three phase values and their sum or their average whereas the single phase masks read only one value (value of phase L1) per measurement quantity you selected.

The software installation procedure and the software manual are supplied in a readme.txt file with your software package. Please consult it for more information.

7.2 OPTION 02: RS-232 AND INTERFACE, OPERATING SOFTWARE, DATA LOGGING, AND IEC-TESTING

Option 02 contains all features of Option 01. Therefore, please read section 7.1.

Additional operating software provides means to acquire and handle data received from a data-logging run (transient response of a system). Data are EXCEL-compatible. Graphs and plots can be generated in EXCEL. The software package of Option 02 also provides means for IEC1000-3-2 current harmonic testing in a three-phase system. The range of harmonics can be set and harmonic currents can be compared against a reference file. The user can edit the values in the reference file.

The software installation procedure and the software manual are supplied in a readme.txt file with your software package.

7.3 OPTION 03: 0-100A THREE PHASE CURRENT SENSOR MODULE

The three-phase current sensor module comprises three broad-band Hall sensors, a DC supply, and three connectors which connect to the clamp inputs L1, L2, and L3 of the Power Analyzer.

WARNING

First disconnect all voltage input leads L1, L2, L3, and L0 on the Power Analyzer before connecting Option 03 to the clamp inputs. At all times **all three clamp inputs must be connected to the Power Analyzer.**

Specifications

Frequency Range:	DC – 100kHz
Current Ranges:	12A / 36A / 120A
Accuracy:	0.5 %, 2Hz-400Hz; 1 %, 400Hz-2kHz
Current Scaling:	0.2
Allowed wire :	7 x 10mm (square)
Isolation Voltage:	3kV, current carrying wire to clamp Lo
Supply:	85V-264V AC, 50Hz-400Hz

Before applying current to your load under test you must first connect the Hall sensor unit to an AC supply. Failure to do so may damage the Hall sensors.

8. EPROM REPLACEMENT, POWER ANALYZER CALIBRATION

8.1 EPROM REPLACEMENT

If you are in possession of a newer software version than is installed in your Power Analyzer you may want to exchange the EPROM. This is how you can proceed:

- STEP 1: Disconnect all wires and cables connected to the Power Analyzer rear panel.
- STEP 2: Remove the Power Analyzer hood by removing 3 screws along the top of the rear panel.
- STEP 3: Lift up the upper half of the case on the rear side and slide it 1cm towards the rear. Now you can remove the hood. The EPROM is towards the front side. You can remove it using a pair of bent pincers. Install the new EPROM and proceed with step 4.

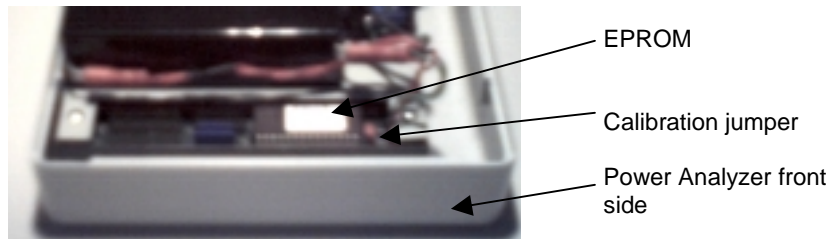

Figure 8.1 Location of EPROM and Calibration Jumper

- STEP 4: Install the hood by sliding it from the rear towards the front. Install the 3 screws on the rear panel.

8.2 POWER ANALYZER CALIBRATION

8.2.1 CALIBRATION CYCLE

We recommend to verify the Power Analyzer calibration once every year or once every two years.

8.2.2 EQUIPMENT NEEDED

A calibrator that will supply voltages 1V-600V and currents 100mA to 2A at 60Hz with 0.02 % accuracy will suffice.

8.2.3 PREPARING FOR CALIBRATION

- STEP 1: Disconnect the power line-cord from Power Analyzer.
- STEP 2: Remove the Power Analyzer hood by removing 3 screws along the top of the rear panel.
- STEP 3: Lift up the upper half (hood) of the case on the rear side and slide it 1cm towards the rear and then remove the hood.
- STEP 4: Remove the red calibration jumper using a pair of pincers or a pair of pliers (Figure 8.1).

CAUTION: Do not forget to reinstall the calibration jumper when calibration is done.
- STEP 5: Put the hood back in place.

8.2.4 VOLTAGE CALIBRATION, CURRENT CALIBRATION, CLAMP CALIBRATION

Select voltage synchronization. Select 1V range. Apply 60Hz voltage to the Power Analyzer voltage inputs.

- a) **Voltage Calibration**, use manual ranging

Select 1V range	Apply 1V/60Hz	Press M1
Select 3V range	Apply 3V/60Hz	Press M1
Select 10V range	Apply 10V/60Hz	Press M1
Select 30V range	Apply 30V/60Hz	Press M1
Select 100V range	Apply 100V/60Hz	Press M1
Select 300V range	Apply 300V/60Hz	Press M1
Select 1000V range	Apply 600V/60Hz	Press M1

b) **Current Calibration**, use manual ranging

Select **IN5A**, Select 100mA range, select current synchronization

Select 100mA range	Apply 100mA/60Hz	Press M2
Select 300mA range	Apply 300mA/60Hz	Press M2
Select 1A range	Apply 1A/60Hz	Press M2
Select 3A range	Apply 2A/60Hz	Press M2
Select 10A range	Apply 2A/60Hz	Press M2

Select **IN50A**, Select 1A range

Select 1A range	Apply 1A/60Hz	Press M2
Select 3A range	Apply 2A/60Hz	Press M2
Select 10A range	Apply 2A/60Hz	Press M2

Select **Clamp**, Select 60mV-range

Select 60mV range	Apply 60mV/60Hz	Press M2
Select 200mV range	Apply 180mV/60Hz	Press M2
Select 600mV range	Apply 600mV/60Hz	Press M2
Select 2V range	Apply 1.800V/60Hz	Press M2
Select 6V range	Apply 6.000V/60Hz	Press M2

c) **Terminate Calibration**

The calibration steps described in a) and b) determine the required internal constants. You must store these constants by pressing key **M3**. Having done this, turn the Power Analyzer off and disconnect all cables connected to it. Remove the hood and **reinstall the calibration jumper**. Install hood and 3 screws on the top side of the rear panel.

EU /UE
KONFORMITÄTSERKLÄRUNG
DECLARATION OF CONFORMITY
DÉCLARATION DE CONFORMITÉ

Wir
We
Nous

Infratek AG

(Name des Anbieters) (supplier's name) (nom du fournisseur)

Weingartenstrasse 6, CH-8707 Uetikon am See

(Anschrift) (address) (adresse)

erklären in alleiniger Verantwortung, dass das Produkt
declare under our sole responsibility that the product
déclarons sous notre seule responsabilité que le produit

MODEL 31 POWER ANALYZER

(Bezeichnung Typ oder Modell, Los-, Chargen- oder Seriennummer, möglichst Herkunft und Stückzahl)
(name, type or model, lot, batch or serial number, possibly sources and numbers of items)
(nom, type ou modèle, no de lot, d'échantillon ou de série, éventuellement sources et nombre d'exemplaires)

auf das sich diese Erklärung bezieht, mit der/den folgenden Norm(en) oder normativen Dokument(en)
übereinstimmt.
to which this declaration relates is in conformity with the following standard(s) or other normative document(s)
auquel se réfère cette déclaration est conforme à la (aux) norme(s) ou autre(s) document(s) normatif(s)

EN61326; EN 50081-1; EN 50082-2; CEI/IEC 1010-1, Amendment 1/2;

(Titel und/oder Nummer sowie Ausgabedatum der Norm(en) oder der anderen normativen Dokumente)
(title and/or number and date of issue of the standard(s) or other normative document(s))
(titre et/ou no et date de publication de la (des) norme(s) ou autre(s) document(s) normatif(s))

Gemäss den Bestimmungen der Richtlinie(n); following the provisions of Directive(s); conformément aux
dispositions de(s) Directive(s)
(falls zutreffend) (if applicable) (le cas échéant)

89/336/EWG

Uetikon am See, Juni 2002 Dr. Hans R. Oppliger

(Ort und Datum der Ausstellung) (Name und Unterschrift oder gleichwertige Kennzeichnung des Befugten)
(Place and date of issue) (name and signature or equivalent marking of authorized person)
(Lieu et date) (nom et signature du signataire autorisé)